



- HVDC 55A at 450VDC
- Max. switching current = 500A
- Contacts sealed in inert gas
- Magnet arc blowout
- Pre-charge relay
- Female M4 power terminals



Contacts

Contact arrangement	SPST-NO-DM
Contact material	T2+Ag
Max. switching voltage	AC/DC 900VDC
Rated load (resistive, cos φ=1)	DC1 55A 450VDC
Max. continuous thermal current	30s 150A
	10s 250A
Max switching current	1 time only 500A 350VDC
Initial contact resistance	max. 1mΩ (at 1A)

Coil

Nominal voltage (see page 2)	DC 6~72VDC
Rated power consumption	hold 3.2W @ 12VDC

Insulation

Insulation resistance	initial	100MΩ (min.)
	life end	50MΩ (min.)
Dielectric strength	coil to contact	2500Vrms / 1mA / 1 min (at sea level)
	contact to contact	2500Vrms / 1mA / 1 min (at sea level)

General Data

Operate time at 20°C	max.	25ms
Bounce time at 20°C	max.	7ms
Release time at 20°C	max.	12ms
Electrical life	Voltage and current dependent - see fig. 1	
Mechanical life	1 x 10 ⁶	

Environmental

Ambient temperature	operating	-40 to +85°C
Relative humidity	5 to 85%RH	
Shock resistance	20G peak, 11ms 1/2 sine	
Vibration resistance	20G sine peak (80 to 2000Hz)	
Dimensions	L x W x H	37.2 x 51.26 (over flanges) x 47.82 (approx.)
Weight	approx.	120g ±5g

Ordering Code

D E V R 0 5 - 5 0 6 1 - S 8 - 1 0 2 4 - R 1

Series

Coil code:

See table 1

Contact material

50: T2+Ag

Contact arrangement

61: SPST-NO

81: SPST-NO (no polarity)

Mounting & terminations

Bottom flange mounting base

S8: M4 Female power terminals

Coil by flying leads

Coil wire length

R: 400mm (standard)

T: 5.9" (150mm)

Coil wire termination

1: None

2: Yazaki 7282-5558-10 Male

Other terminations to special order

Coil Data

Table 1

Coil code	Nominal voltage (VDC)	Must operate voltage max. (VDC@ 20°C)	Max. allowable voltage (VDC)	Must release voltage min. (VDC)	Coil resistance $\Omega \pm 5\%$ (at 20°C)	Coil Current (mA)	Coil power (W @ 20°C)
1006	6	4.8	7.2	0.6	11	545.5	3.3
1012	12	9.6	14.4	1.2	45	266.7	3.2
1024	24	19.2	28.8	2.4	167	143.7	3.45
1028	28	22.4	33.6	2.8	240	116.7	3.3
1036	36	28.8	43.2	3.6	400	90.0	3.2
1048	48	38.4	57.6	4.8	630	76.2	3.66
1072	72	57.6	86.4	7.2	1600	45.0	3.2

Electrical Performance

Fig. 1

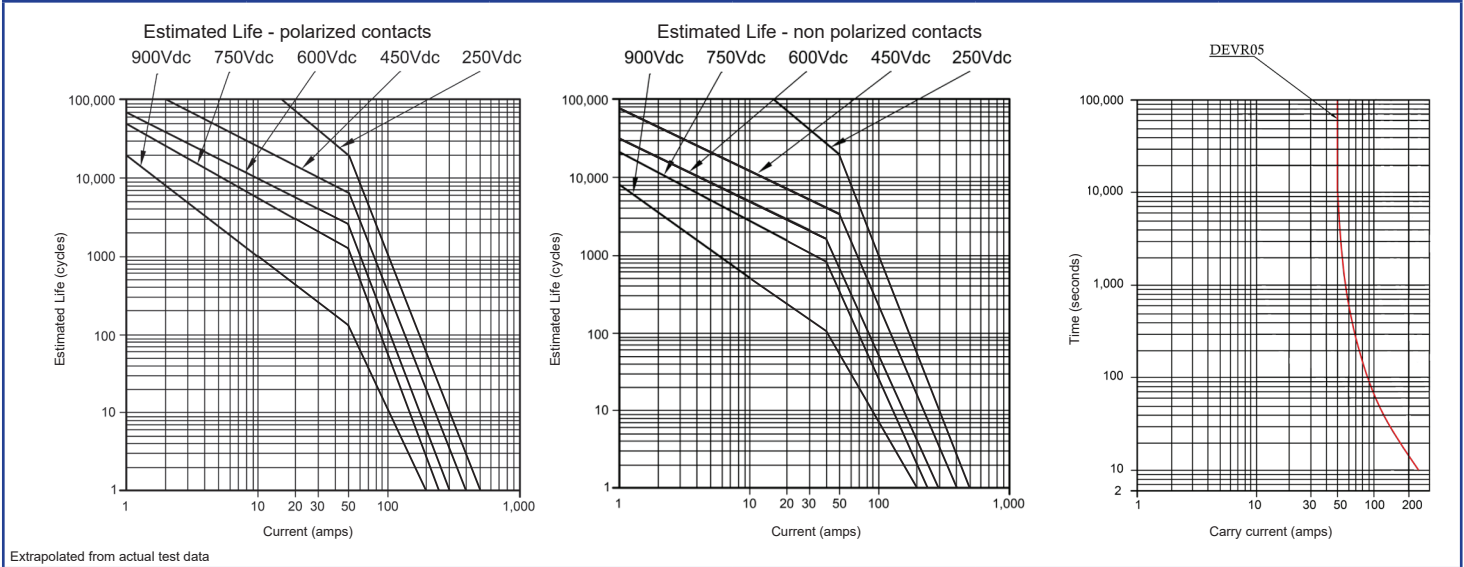

Dimensions (mm)

Fig. 2

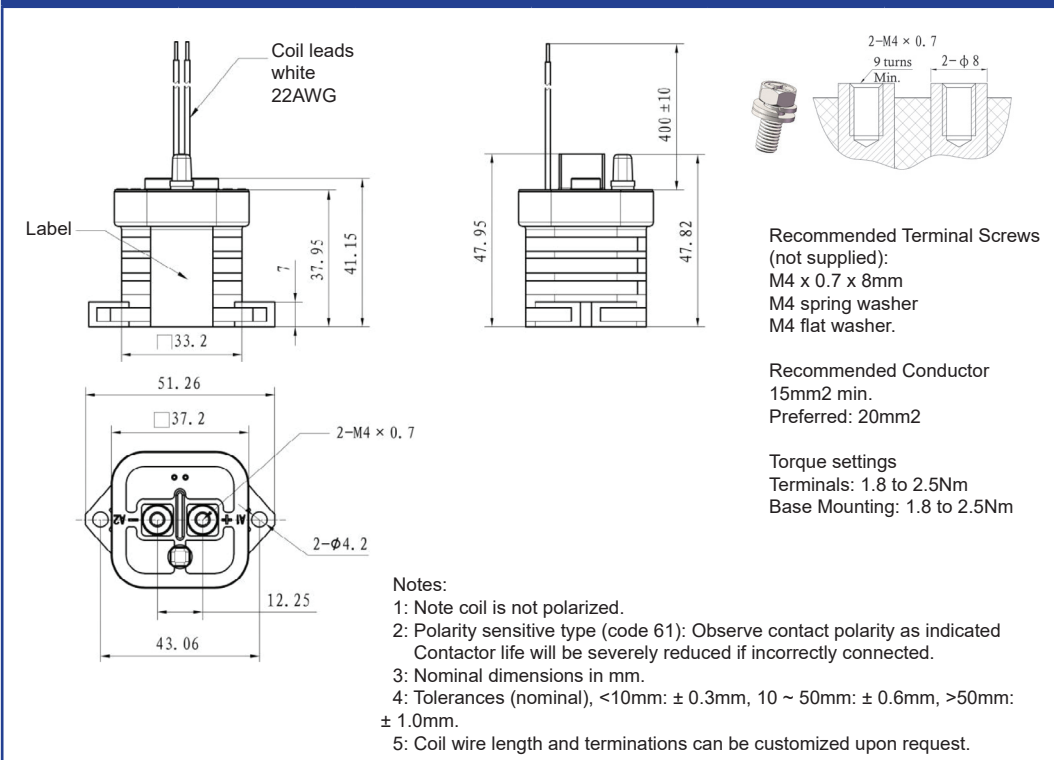

Circuit Diagram

Fig. 3

